

# Codimension Two Bifurcation Observed in a Phase Converter Circuit

Hiroyuki KITAJIMA<sup>†</sup>, Student Member, Tetsuya YOSHINAGA<sup>††</sup>,  
and Hiroshi KAWAKAMI<sup>†</sup>, Members

**SUMMARY** We investigate bifurcations of the periodic solution observed in a phase converter circuit. The system equations can be considered as a nonlinear coupled system with Duffing's equation and an equation describing a parametric excitation circuit. In this system there are two types of solutions. One is with  $x = y = 0$  which is the same as the solution of Duffing's equation (correspond to uncoupled case), another solution is with  $xy \neq 0$ . We obtain bifurcation sets of both solutions and discuss how does the coupling change the bifurcation structure. From numerical analysis we obtain a codimension two bifurcation which is intersection of double period-doubling bifurcations. Periodic solutions generated by these bifurcations become chaotic states through a cascade of codimension three bifurcations which are intersections of D-type of branchings and period-doubling bifurcations.

**Key words:** codimension two bifurcation, codimension three bifurcation, coupled system, nonlinear dynamical system

## 1. Introduction

In this paper we study codimension two bifurcations observed in a forced oscillatory circuit containing saturable inductors, which is called a phase converter circuit, see Fig. 1 and Ref. [1]. The normalized circuit equations are described by

$$\begin{aligned} \frac{dx}{dt} &= y \\ \frac{dy}{dt} &= -ky - (c_0 + c_1)x - \frac{1}{4}c_3(x^2 + 3u^2)x \\ \frac{du}{dt} &= v \\ \frac{dv}{dt} &= -kv - \left(\frac{1}{3}c_0 + c_1\right)u - \frac{1}{4}c_3(x^2 + 3u^2)u \\ &\quad + B \cos t + B_0 \end{aligned} \quad (1)$$

where

$$x = \phi_a - \phi_b, \quad u = \phi_c, \quad k = g/\omega C, \quad B \propto E, \quad B_0 \propto E_0.$$

In this circuit, the characteristic of inductor is assumed to be a cubic function, i.e., the relation between current  $i$  and flux  $\phi$  is assumed to be  $i = c_1\phi + c_3\phi^3$ . Equations (1) can be considered as a nonlinear coupled system with Duffing's equation and an equation describing

a parametric excitation circuit. Hence we may observe various complicated behavior such as chaotic state due to a period-doubling process of parametric excitation, codimension two bifurcations, the coexistence of several periodic oscillations which are correlated with jump and hysteresis behaviors and the fundamental, higher-harmonic and sub-harmonic resonances.

In particular we are interested in codimension two bifurcations. In the neighborhood of a codimension two bifurcation point the dynamical behavior exhibits complicated features and some types of codimension two bifurcations may relate to the generation of chaotic states. Numerical analysis shows that a new route to chaos through a cascade of codimension three bifurcations.

## 2. Method of Analysis

Equations (1) are rewritten as:

$$\dot{x} = f(t, x, \lambda) \quad (2)$$

In Eqs. (1),  $f$  is periodic in  $t$  with period  $2\pi$ :

$$f(t + 2\pi, x, \lambda) = f(t, x, \lambda) \quad (3)$$

We assume that Eqs. (1) has a solution  $x(t) = \varphi(t, x_0, \lambda)$  with initial condition  $x_0 : x(0) = \varphi(0, x_0, \lambda) = x_0$ . Since  $f$  has the period  $2\pi$ , we can naturally define the Poincaré mapping  $T_\lambda$  from the state space  $R^4$  into itself:

$$T_\lambda : R^4 \rightarrow R^4, x_0 \mapsto T_\lambda(x_0) = \varphi(2\pi, x_0, \lambda) \quad (4)$$

If a solution  $\varphi(t, x_0, \lambda)$  is a periodic, then the point  $x_0$  is a fixed point of  $T_\lambda$ :

$$F_\lambda(x_0) := x_0 - T_\lambda(x_0) = 0 \quad (5)$$

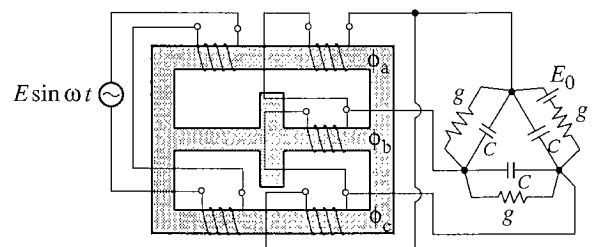

Fig. 1 A phase converter circuit.

Manuscript received February 1, 1996.

<sup>†</sup>The authors are with the Faculty of Engineering, University of Tokushima, Tokushima-shi, 770, Japan.

<sup>††</sup>The author is with the School of Medical Sciences, University of Tokushima, Tokushima-shi, 770, Japan.

Computation of a periodic solution of Eqs. (1) has now been reduced to find  $x_0 \in R^4$  satisfying Eq. (5).

The generic bifurcations of the periodic solution are known as codimension one bifurcations: Tangent, period-doubling, Neimark-Sacker bifurcations. At a bifurcation value of parameters, if a periodic solution satisfies two bifurcation conditions, then the bifurcation refers to as a codimension two bifurcation. The degenerate bifurcation: D-type of branching observed in the system which possess a symmetrical property is also called codimension two bifurcation. These bifurcation sets can be traced out by solving the fixed point equation and bifurcation condition simultaneously [2].

We use the notation  ${}_kD^m$  (resp.  ${}_kI^m$ ) denoting a type of  $m$  periodic points of  $T_\lambda$  having even (resp. odd) number of characteristic multipliers on the real axis  $(-\infty, -1)$ , and  $k$  indicates the number of characteristic multiplier outside the unit circle in the complex plane.

### 3. Results

Now we show some numerical results of bifurcation diagrams and behavior of the solutions observed in Eqs. (1). We use the following notations in bifurcation diagrams:  $G_k^m$ ,  $I_k^m$  and  $D_k^m$  represent respectively tangent, period-doubling bifurcation and D-type of branching of  $m$ -periodic point and  $k$  denotes the number to distinguish several bifurcation sets of the same period.

#### 3.1 Decision of the System Parameters

Firstly we explain how to decide the system parameters in Eqs. (1). In the following we fix the several parameters in Eqs. (1) as

- (a)  $c_0 = c_1 = 0.0, c_3 = 1.0,$
- (b)  $k = 0.1.$

The reasons are as follows:

- (a) We choose the same value in [2],
- (b) We obtain 3-dimensional bifurcation diagram shown in Fig. 2. When  $k$  is larger than 0.3, the intersection of period-doubling bifurcations disappear. If  $k$  is less than 0.1, bifurcation structure would be more complicated.

Thus we consider the bifurcation problem in the parameter plane for  $B$  and  $B_0$  with  $k = 0.1$ .

#### 3.2 Bifurcation of Uncoupled Case

Secondly we show a bifurcation diagram, see Fig. 3, of the solution with  $x = y = 0$ , i.e., the solution of Duffing's equation of  $u$  and  $v$ . Thus the diagram is the same as that of Duffing's equation. In the shaded region, there

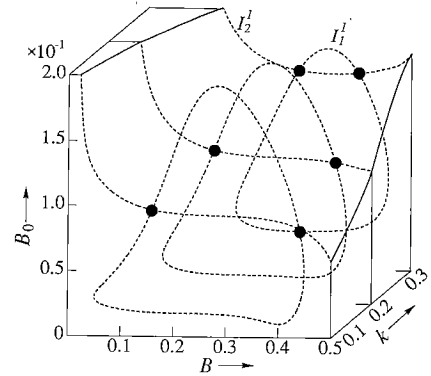

**Fig. 2** Bifurcation diagram in  $(B, B_0, k)$  space. Dashed curves and circled points indicate period-doubling bifurcations and codimension two bifurcations, respectively.

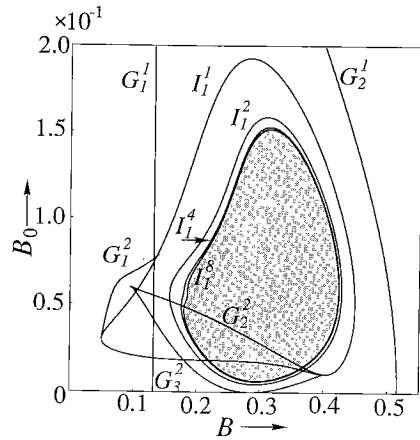
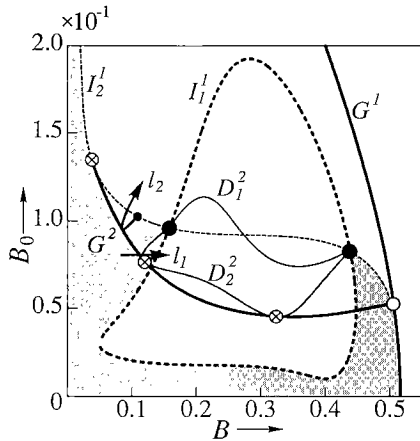

**Fig. 3** Bifurcation diagram of the periodic points of  $T_\lambda$  with  $x = y = 0$ .

exists chaotic state by a cascade of period-doubling bifurcations. In the next section we will describe how does the coupling change this bifurcation structure.

#### 3.3 Bifurcation of Coupled Case

Thirdly we show the change of the bifurcation structure under the influence of coupling term. In Fig. 4 a stable fixed point with  $x = y = 0$  exists in the shaded region. By increasing the parameter  $B$  along the line  $l_1$ , 2-periodic points with  $x = y = 0$  are generated on the period-doubling bifurcation curve  $I_1^1$ , see Fig. 5 (a). This bifurcation with  $x = y = 0$  is therefore the same as the bifurcation of Duffing's equation shown in Fig. 3. On the other hand when  $B$  and  $B_0$  change along the curve  $l_2$ , the period-doubling bifurcation  $I_2^1$  generates 2-periodic points with  $xy \neq 0$ , see Fig. 5 (b), which corresponds to the parametric excitation phenomenon in the original circuit. At black circles in Fig. 4 the two period-doubling bifurcations  $I_1^1$  and  $I_2^1$  intersect, which are called codimension two bifurcations of double period-doubling bifurcations [3]. In the neighborhood of this point D-type of branchings



**Fig. 4** Bifurcation diagram for Eqs. (1). Open circle indicate the codimension two bifurcation called *TP*-bifurcation in [7]. From this point tangent bifurcation of 2-periodic points appear.

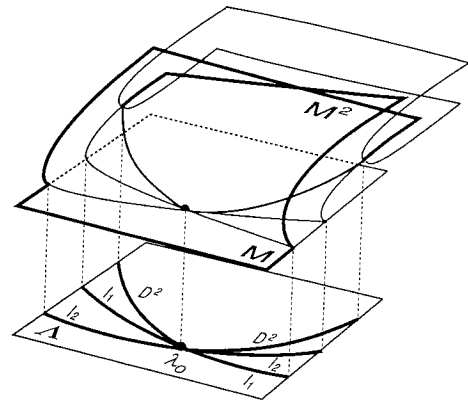

**Fig. 6** Manifold of fixed point  $M$  and manifold of 2-periodic points  $M^2$  in the neighborhood of  $\lambda_0$ : Intersection of double period-doubling bifurcations. In the manifold heavy and light curves represent stable and unstable manifolds.

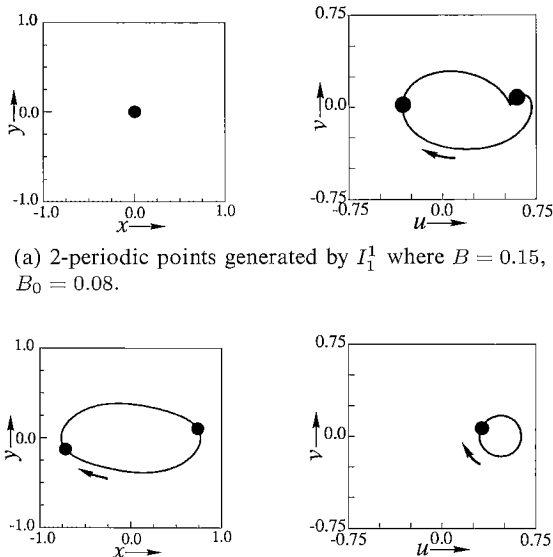

(a) 2-periodic points generated by  $I_1^1$  where  $B = 0.15$ ,  $B_0 = 0.08$ .

(b) 2-periodic points generated by  $I_2^1$  where  $B = 0.12$ ,  $B_0 = 0.1$ .

**Fig. 5** Trajectories generated by the period-doubling bifurcations:  $I_1^1$  and  $I_2^1$ . The points marked  $\bullet$  and the arrow indicate the 2-periodic points of  $T_\lambda$  and the direction of trajectory, respectively.

$D_2^2$  and  $D_1^2$  necessarily appear, see Fig. 6 [4].

Figure 7 shows the detail bifurcation diagram of Fig. 4. In the figure we see successive codimension three bifurcations which are the intersections of D-type of branchings and period-doubling bifurcations. The mechanism of generation of successive codimension three bifurcations are as follows:

(1) A cascade of period-doubling bifurcation  $I_1^{2^n}$  ( $n = 1, 2, 3$ ) of  $2^n$  periodic points with  $x = y = 0$  exists, see Fig. 3. When  $x = y = 0$ , Eqs. (1) reduces to Duffing's equation of  $u$  and  $v$  as mentioned Sect. 3.2.

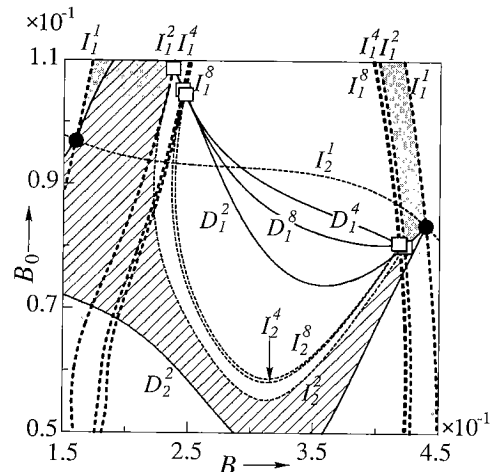
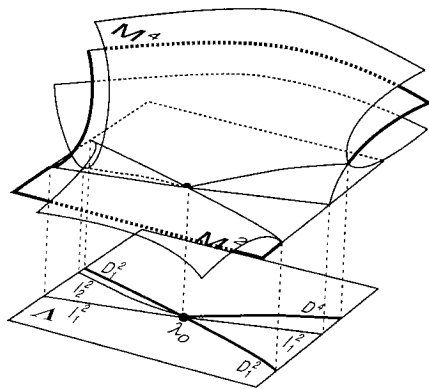

**Fig. 7** Detailed bifurcation diagram of Fig. 4. The symbols square indicate intersection of D-type of branching and period-doubling bifurcation which is called codimension three bifurcation. Two cascades of codimension three bifurcations are observed.

(2) Under the influence of coupling term another period-doubling bifurcation  $I_2^1$  appears. At the intersecting point of  $I_1^1$  and  $I_2^1$ , codimension two bifurcation is generated, and from this intersecting point D-type of branchings  $D_1^2$  and  $D_2^2$  appear.

(4) Bifurcation curves  $D_1^{2^n}$  and  $I_1^{2^n}$  intersect at square marked points in Fig. 7 which are codimension three bifurcations. In the neighborhood of this point, D-type of branching of  $2^{n+1}$ -periodic points  $D_1^{2^{n+1}}$  and period-doubling bifurcation of  $2^n$ -periodic points  $I_2^{2^n}$  necessarily appear, see Fig. 8. Similarly  $D_1^{2^{n+1}}$  and  $I_1^{2^{n+1}}$  will intersect on the cascade process of period-doubling bifurcation.

(5) By repeating (4) the successive codimension three bifurcations occur and finally become chaotic states.



**Fig. 8** Manifolds of 2-periodic points  $M^2$  and manifolds of 4-periodic points  $M^4$  in the neighborhood of  $\lambda_0$ : Intersection of period-doubling bifurcation and D-type of branching.  $\Lambda$  indicates parameter plane. In the manifold heavy and light curves represent stable and unstable manifolds.

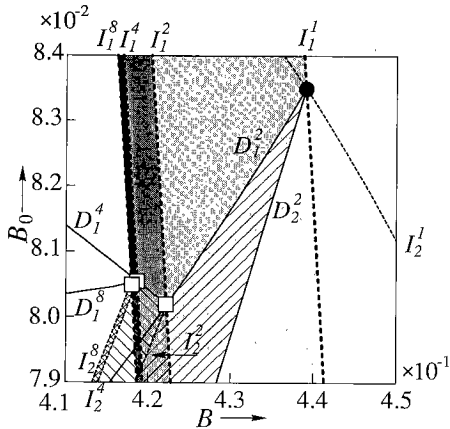
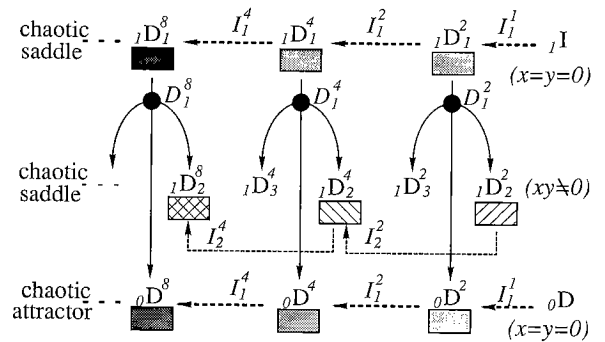

**Fig. 9** Enlarged bifurcation diagram of Fig. 7.

In Fig. 9 we see that bifurcation set  $D^{2^n}$  forms a zigzag branch. A similar tree-like pattern is found in [5] on a period-doubling cascade of one-dimensional dynamical system. This property can be explained by a renormalization of a family of functions on the cascade [6]. In Fig. 9 we observe three types of phase transitions to chaos, see Fig. 10. One of them is from a stable periodic point to a chaotic attractor. Others are from periodic points of saddle type to chaos. The latter chaotic states may have both stable and unstable invariant manifolds. Hence the chaotic state can be called a chaotic saddle and it is unstable.

**4. Concluding Remarks**

We have investigated global properties of bifurcation sets of periodic solutions observed in the phase converter circuit. This system is a coupled system of Duffing's circuit and a parametric excitation circuit. We show how does the coupling change the bifurcation structure. The main results of our analysis are as fol-



**Fig. 10** Schematic diagram of phase transitions observed in Fig. 9. Bifurcations written by italic letters and shades are correspond to those of Fig. 9. Solid and dashed lines indicate stable and unstable periodic points, respectively.

lows: We obtain a codimension two bifurcation which is intersection of double period-doubling bifurcations. Periodic solutions generated by these bifurcations become chaotic states through a cascade of codimension three bifurcations which are intersections of D-type of branchings and period-doubling bifurcations.

Further research is needed to study a detailed mechanism of generating the double period-doubling bifurcations and classification of the codimension three bifurcations.

**References**

- [1] H. Kawakami, "Bifurcation and chaotic state in forced oscillatory circuits containing saturable inductors," *Int. J. of Applied Electromagnetics in Materials*, vol.3, pp.215-220, 1992.
- [2] H. Kawakami, "Bifurcation of periodic responses in forced dynamic nonlinear circuits: Computation of bifurcation values of the system parameters," *IEEE Trans. Circuits & Sys.*, vol.CAS-31, no.3, pp.248-260, March 1984.
- [3] H. Kitajima, T. Yoshinaga, and H. Kawakami, "Synchronization in two coupled oscillators with three ports," *Proc. NOTLA'94*, pp.89-92, Ibusuki, Japan, Oct. 1994.
- [4] T. Yoshinaga H. Kitajima, and H. Kawakami, "Bifurcations in a ring of Coupled Quadratic maps," *Spring Conference of IEICE*, vol.SA-2-7, March 1995.
- [5] T. Yoshinaga and H. Kawakami, "Codimension two bifurcation and its computational algorithm," in *Bifurcation and Chaos: Theory and Applications*, ed. J. Awrejcewicz, Springer-Verlag, Berlin, pp.97-132, 1995.
- [6] T. Yoshinaga and H. Kawakami, "A property of mean value defined on period doubling cascade," in *Bifurcation phenomena in nonlinear systems and theory of dynamical systems*, ed. H. Kawakami, *Advanced Series in Dynamical systems*, World Scientific, Singapore, vol.8, pp.183-195, 1989.
- [7] T. Yoshinaga and H. Kawakami, "Codimension two bifurcation problems in forced nonlinear circuits," *IEICE Trans.*, vol.E73, pp.817-824, June 1990.
- [8] N. Kawaguchi, "Qualitative analysis of high dimensional nonlinear system," *Master thesis of Tokushima University*, March 1984.



**Hiroyuki Kitajima** was born in Tokushima, Japan, on June 25, 1970. He received the B.Eng. and M.Eng. degrees in Electrical and Electronic Engineering from Tokushima University, in 1993 and 1995 respectively. He is presently working toward the Ph.D. degree at Tokushima University. He is interested in bifurcation problems.

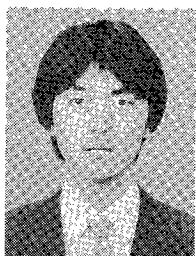

**Tetsuya Yoshinaga** was born in Tokushima, Japan, on April 23, 1961. He received the B.Eng. and M.Eng. degrees from Tokushima University, Tokushima, Japan, in 1984 and 1986, respectively, and the Dr. Eng. degree from Keio University, Yokohama, Japan, in 1992, all in electronic engineering. Since 1989, he has been engaged in research at School of Medical Sciences, Tokushima University on nonlinear circuit. Particularly, his

current research interests are in bifurcation problems.

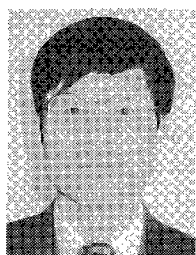

**Hiroshi Kawakami** was born in Tokushima, Japan, on December 6, 1941. He received the B.Eng. from Tokushima University, Tokushima, Japan, in 1964, the M.Eng. and Dr. Eng. degrees from Kyoto University, Kyoto, Japan, in 1966 and 1974, respectively, all in electrical engineering. Presently, he is Professor of Electrical and Electronic Engineering, Tokushima University, Tokushima, Japan. His interest is qualitative prop-

erties of nonlinear circuits.